

Gas engine must be purchased separately.

## Direct-Drive Plunger Pumps

### Models

**5DX30G1, 5DX35G1  
5DX40G1, 5DX50G1**

### FEATURES

- Triplex plunger design provides a smooth fluid flow.
- Specially formulated Hi-Pressure V-Packing and concentrically ground ceramic plungers assure maximum seal life.
- Built-in flange mount for easy, direct mounting to most gas engines. Eliminates the need for pulleys, belts, gearboxes.
- Modular Regulating Unloader with built-in by-pass and flow-thru screws is standard to assure system pressure control and pump protection.
- Optional direct mounting fixed or adjustable Chemical Injector for cleaning flexibility.

### SPECIFICATIONS

	U.S. Measure	Metric Measure
<b>MODEL 5DX30G1</b>		
Flow .....	3.0 GPM	(11.4 L/M)
Pressure Range .....	100 to 3200 PSI	(7 to 220 BAR)
Stroke .....	0.252"	(6.4 mm)
<b>MODEL 5DX35G1</b>		
Flow .....	3.5 GPM	(13.2 L/M)
Pressure Range .....	100 to 3200 PSI	(7 to 220 BAR)
Stroke .....	0.311"	(7.9 mm)
<b>MODEL 5DX40G1</b>		
Flow .....	4.0 GPM	(15.0 L/M)
Pressure Range .....	100 to 3200 PSI	(7 to 220 BAR)
Stroke .....	0.354"	(9.0 mm)
<b>MODEL 5DX50G1</b>		
Flow .....	5.0 GPM	(19.0 L/M)
Pressure Range .....	<b>100 to 2500 PSI</b>	<b>(175 BAR)</b>
Stroke .....	0.441"	(11.2 mm)

### COMMON PUMP SPECIFICATIONS

Max. RPM .....	3200 RPM	(3200 RPM)
Engine Mounting Face .....	6.5"	(6.5")
Max. Inlet Pressure .....	Flooded to 75 PSI	(Flooded to 5.25 BAR)
Bore .....	0.630"	(16 mm)
Shaft Diameter (Hollow) .....	1"	(25.4 mm)
Max. Fluid Temperature .....	140°F	(62°C)
Crankcase Capacity .....	22.65 oz.	(0.67 L)
Inlet Ports (2) .....	1/2" NPT	(1/2" NPT)
Discharge Ports (2) .....	3/8" NPT	(3/8" NPT)
Weight (Pump Only) .....	24.55 lbs.	(11.1 kg)
Dimensions (Pump Only) ....	10.83" x 7.08" x 6.38"	(275 x 180 x 162 mm)

### HORSEPOWER REQUIREMENTS

MODEL	FLOW		PRESSURE			RPM
	U.S. GPM	L/M	PSI	PSI	PSI	
			2000	2500	3200	
		BAR	BAR	BAR		
<b>5DX30G1</b>	3.0	11.4	4.2	5.2	6.6	3200
<b>5DX35G1</b>	3.5	13.2	4.8	6.0	7.7	3200
<b>5DX40G1</b>	4.0	15.0	5.5	6.9	8.8	3200
<b>5DX50G1</b>	5.0	19.0	6.9	8.6	N/A	3200

<b>DETERMINING THE PUMP R.P.M.</b>	$\frac{\text{Rated G.P.M.}}{\text{Rated R.P.M.}}$	=	$\frac{\text{"Desired" G.P.M.}}{\text{"Desired" R.P.M.}}$
<b>DETERMINING THE REQUIRED H.P.</b>	$\frac{\text{GPM x PSI}}{1460}$	=	Electric Brake H.P. Required
<b>DETERMINING MOTOR PULLEY SIZE</b>	$\frac{\text{Motor Pulley O.D.}}{\text{Pump R.P.M.}}$	=	$\frac{\text{Pump Pulley O.D.}}{\text{Motor R.P.M.}}$

Note: Consult engine manufacturer when using gas or diesel engine. Refer to pump Service Manual for important Inlet Condition Check-List, Start-up Procedure, Tech Bulletins and Pump Maintenance information.

*"Customer confidence is our greatest asset"*

# EXPLODED VIEW

June 1999

# 5DX PLUNGER PUMP MODELS

5DX30G1, 5DX35G1, 5DX40G1, 5DX50G1

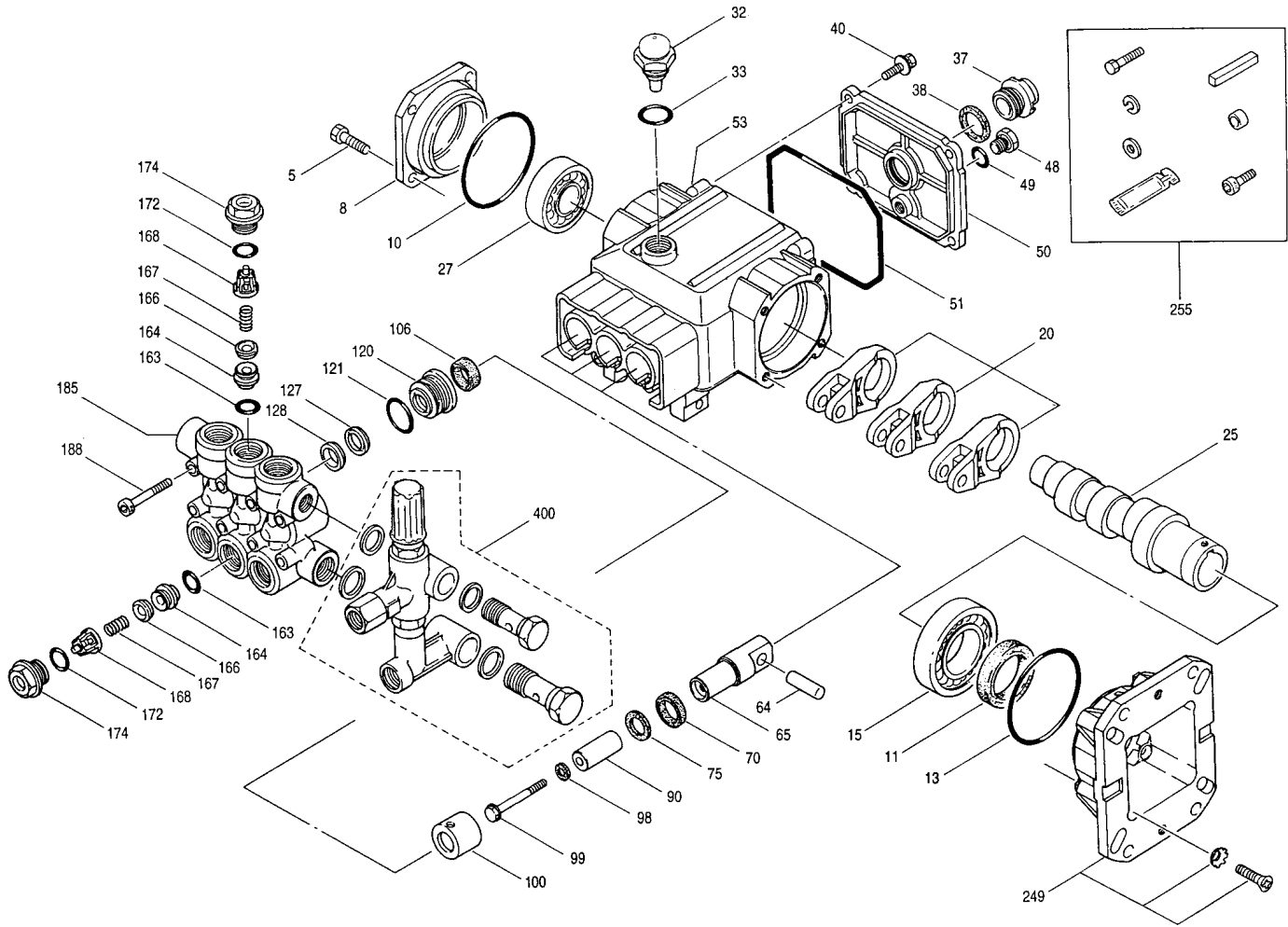

## PARTS LIST

ITEM	P/N	MATL	DESCRIPTION	QTY	ITEM	P/N	MATL	DESCRIPTION	QTY
5	92521	STZP	Screw, HHC (M8x20)	4	106	48222	NBR	Seal, LPS w/S-Spg	3
8	46461	AL	Cover, Bearing	1	120	46471	BB	Case, Seal	3
10	14037	NBR	O-Ring, Bearing Cover	1	121	13980	NBR	O-Ring, Seal Case	3
11	46419	NBR	Seal, Oil, Crankshaft	1	127	46617	SNG	V-Packing	3
13	14037	NBR	O-Ring, Bearing Cover	1	128	46618	NY	Adapter, Male	3
15	146421	STL	Bearing, Ball - Inner	1	163	17547	NBR	O-Ring, Seat - 85	6
20	46677	ZZ	Connecting Rod	3	164	46658	S	Seat	6
25	46985	CM	Crankshaft (6.4 mm) 30G1	1	166	46429	S	Valve	6
	46551	CM	Crankshaft (7.9 mm) 35G1	1	167	43750	S	Spring	6
	46460	CM	Crankshaft (9.0 mm) 40G1	1	168	46583	NY	Retainer	6
	48468	CM	Crankshaft (11.2 mm) 50G1	1	172	17615	NBR	O-Ring, Valve Plug - 75	6
27	14480	STL	Bearing, Ball - Outer	1	174	46388	BB	Plug, Valve	6
32	46798		Cap, Domed Oil Filler	1	185	46526	BB	Head, Manifold	1
33	14179	NBR	O-Ring, Oil Filler Cap	1	188	87868	STZP	Screw, HSH (M8x107)	8
37	43987		Gauge, Oil Bubble	1	249	46679	AL	Flange, Mount	1
38	44428	NBR	Gasket, Flat Flex.	1	46123	STZP	Lockwasher, Toothed (M8)	4	
40	92519	STZP	Screw, HHC (M6x16)	4	46403	STZP	Screw, FH (M8x25)	4	
48	25625	STCP	Plug, Drain (1/4"x11)	1	255	30519	STZP	Kit, Bolt Mount	1
49	23170	NBR	O-Ring, Drain Plug	1	34100	STZP	Screw (3/8-16x1-3/8")	4	
50	46379	AL	Cover, Crankcase	1	30921	STZP	Lockwasher, Split (3/8")	4	
51	14048	NBR	O-Ring, Crankcase Cover	1	30980	STZP	Washer, Flat (3/8")	4	
53	46454	AL	Crankcase	1	6106	—	Antiseize Lubricant	1	
64	46404	S	Pin, Rist	3	45217	STL	Key (1/4"x1/4"x2-1/2") HD	1	
65	46728	BBPCP	Rod, Plunger	3	34042	AL	Spacer	4	
70	29257	NBR	Seal, Oil, Crankcase	3	87788	STZP	Screw, Set (M5x8)	1	
75	46732	NBR	Slinger, Barrier	3	300	34062	NBR	Kit, Seal (Incls: 98,106,121,127,128)	1
90	46727	CC	Plunger	3	310	34060	NBR	Kit, Valve (Incls: 163,164,166,167,168,172)	2
98	46730	NBR	Washer Seal, Plunger Retainer	3	400	7655	BB	Modular Unloader Assembly	1
99	46729	S	Retainer, Plunger	3		7659	BB	Modular Unloader Assembly w/Q.S., T.V.	1
100	46408	NY	Retainer, Seal	3					

Italics are optional items.

See Tech Bulletins 24, 60 and 74 for additional information.

MATERIAL CODES (Not Part of Part Number): AL=Aluminum BB=Brass BBPCP=Brass/Chrome Plated CC=Ceramic CM=Chrome-moly NBR=Medium Nitrile (Buna-N) NY=Nylon S=304SS SNG=Special Buna Blend STCP=Steel/Chrome Plated STL=Steel STZP=Steel/Zinc Plated ZZ=Zamak

## 7655 UNLOADER

Specifications	U.S. Measure	Metric Measure
GPM.....	2.0-5.0 GPM	(7.6-19 L/M)
PSI.....	700-3200 PSI	(50-220 BAR)
Inlet Port - Side.....	3/8" NPTF	(3/8" NPTF)
Discharge Port - Front.....	3/8" NPTF	(3/8" NPTF)
By-pass Port - Bottom.....	3/8" NPTF	(3/8" NPTF)
Weight.....	21.4 oz.	(0.67 kg)
Dimensions.....	3.00 x 1.0 x 4.25"	(76 x 25 x 108 mm)
See individual Data Sheet for Q.S., T.V.		

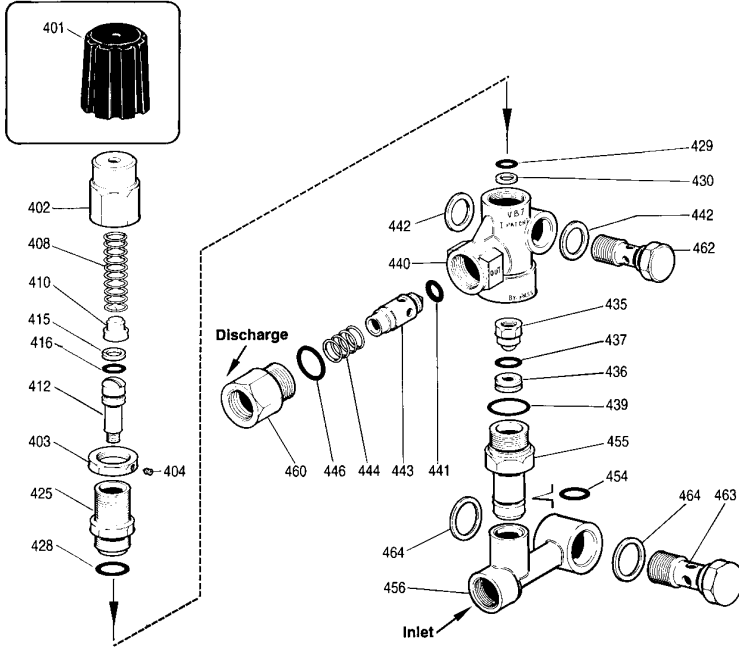

### PARTS LIST

ITEM	P/N	MATL	DESCRIPTION	QTY.
401	32088	NY	Cap, Black	1
402	33859	BB	Cap, Hex Adjusting	1
403	33857	BB	Nut, Locking (M18x1)	1
404	33061	STZP	Screw, Set (M4x4)	1
408	33294	STZP	Spring, White	1
410	32819	BB	Guide, Spring	1
412	33860	S	Stem, Valve	1
415	33278	PTFE	Back-up-Ring, Stem	1
416	33571	NBR	O-Ring, Stem	1
425	33861	BB	Retainer, Piston	1
428	33043	NBR	O-Ring, Retainer	1
429	33571	NBR	O-Ring, Stem	2
430	33276	PTFE	Back-up-Ring, Stem	1
435	33853	S	Valve and Ball Assembly (M6)	1
436	33862	S	Seat	1
437	32008	FPM	O-Ring, Seat	1
439	33044	NBR	O-Ring, By-pass Fitting - 85	2
440	—	BB	Valve Body	1
441	32851	NBR	O-Ring, Flow Balancer	1
442	33856	STL	Washer, Seal (3/8")	2
443	33852	BB	Balancer, Flow	1
444	33843	S	Spring, Flow Balancer	1
446	33043	NBR	O-Ring, Discharge Fitting	1
454	33569	FPM	O-Ring, By-pass Fitting	1
455	33863	BB	Fitting, By-pass	1
456	33850	BB	Manifold, By-pass (1/2" NPT)	1
460	33855	BB	Fitting, Discharge (3/8" NPTF)	1
462	33892	BB	Screw, Flow-thru (3/8" NPT)	1
463	33894	BB	Screw, Flow-thru (1/2" NPT)	1
464	33854	STL	Washer, Seal (1/2")	2
468	33098	NBR	Kit, O-Ring	1

*(Incls:415,416,428,429,430,437,439,441,446,454)*

*Italics are optional items.*

MATERIAL CODES (Not Part of Part Number):

BB=Brass FPM=Fluorocarbon (Viton®) NBR=Medium Nitrile (Buna-N)  
 NY=Nylon PTFE=Polytetrafluoroethylene (Teflon®) S=304SS SS=316SS  
 STL=Steel STZP=Steel/Zinc Plated

## Adjustable CHEMICAL INJECTORS

Specifications	U.S. Measure	Metric Measure	U.S. Measure	Metric Measure
<b>MODEL</b>		<b>7223</b>		<b>7224</b>
Flow.....	3.0-4.0 GPM	(11.4-15 L/M)	4.0-5.0 GPM	(15-19 L/M)
Nozzle Orifice.....	2.1 mm	(2.1 mm)	2.3 mm	(2.3 mm)
Hose Barb.....	1/4"	(1/4")	1/4"	(1/4")
Inlet Port.....	M22x1.5	(M22x1.5)	M22x1.5	(M22x1.5)
Discharge Port.....	3/8" NPTM	(3/8" NPTM)	3/8" NPTM	(3/8" NPTM)
Weight.....	6.3 oz.	(0.18 kg)	6.3 oz.	(0.18 kg)
Dimensions.....	2.0x1.0x3.0"	(50x25x76 mm)	2.25x1.0x2.63"	(57x25x67 mm)

## Fixed CHEMICAL INJECTORS

Specifications	U.S. Measure	Metric Measure	U.S. Measure	Metric Measure
<b>MODEL</b>		<b>7233</b>		<b>7234</b>
Flow.....	3.0-4.0 GPM	(11.4-15 L/M)	4.0-5.0 GPM	(15-19 L/M)
Nozzle Orifice.....	2.1 mm	(2.1 mm)	2.3 mm	(2.3 mm)
Hose Barb - Ext.....	1/4"	(1/4")	1/4"	(1/4")
Hose Barb - Int.....	8/32" UNCF	(8/32" UNCF)	8/32" UNCF	(8/32" UNCF)
Inlet Port.....	M22x1.5	(M22x1.5)	M22x1.5	(M22x1.5)
Discharge Port.....	3/8" NPTM	(3/8" NPTM)	3/8" NPTM	(3/8" NPTM)
Weight.....	6.3 oz.	(0.18 kg)	6.3 oz.	(0.18 kg)
Dimensions.....	2.0x1.0x3.0"	(50x25x76 mm)	2.25x1.0x2.63"	(57x25x67 mm)

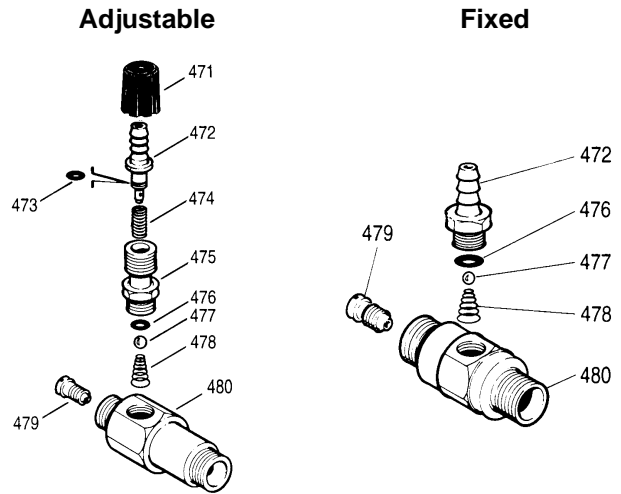

### PARTS LIST

ITEM	P/N	MATL	DESCRIPTION	MODEL USED	QTY.
471	32940	BB	Collar, Adjustment	7223, 7224	1
472	32941	BB	Barb, Hose	7223, 7224	1
	33505	BB	Barb, Hose	7233, 7234	1
473	33503	NBR	O-Ring, Hose Barb	7223, 7224	1
474	33500	S	Spring	7223, 7224	1
475	—	BB	Ball/Seat Retainer	7223, 7224	1
476	33504	FPM	O-Ring, Retainer	All Models	1
477	34620	SS	Ball	All Models	1
478	33501	SS	Spring	All Models	1
479	32373	S	Injector Orifice (2.1 mm)	7223, 7233	1
	32374	S	Injector Orifice (2.3 mm)	7224, 7234	1
480	—	BB	Body, Unloader Mount	—	1
—	33480	BB	Fixed Barb Assembly	7233, 7234	1
483	33490	NY	Chemical Metering Kit	7233, 7234	1

*Italics are optional items.*

MATERIAL CODES (Not Part of Part Number):

BB=Brass FPM=Fluorocarbon (Viton®) NBR=Medium Nitrile (Buna-N)  
 NY=Nylon S=304SS SS=316SS

### CHEMICAL INJECTOR PERFORMANCE CHART

Desired Pump Flow	Orifice Size	Injector Model	Lo-Pressure Nozzle (Maximum injecting pressure less hose friction loss)	Max. Chem. Draw (0 PSI) (Downstream)	Hi-Press Nozzle "Deduction" (Press drop across Inj.)
3.5	2.1 mm	7223, 7233	300 PSI	50 oz/min	200 PSI
3.5	2.3 mm	7224, 7234	185 PSI	56 oz/min	175 PSI
4.0	2.1 mm	7223, 7233	375 PSI	54 oz/min	250 PSI
4.0	2.3 mm	7224, 7234	225 PSI	50 oz/min	225 PSI
5.0	2.3 mm	7224, 7234	300 PSI	50 oz/min	350 PSI

## INSTALLATION:

A Modular Regulating Unloader comes with each DX pump to provide system pressure regulation and pump protection. The Unloader is mounted directly onto the pump with flow-thru screws.

An optional, specially ported, Chemical Injector may be installed directly onto the discharge of the unloader. Remove the discharge fitting, o-ring check valve and spring from the unloader. Insert check valve and spring into the injector and thread onto the unloader. **Discard the o-ring and discharge fitting.**

## OPERATION:

Set the unloader while the high pressure system is turned on. Adjust in small increments until the desired system pressure is reached. Install a pressure gauge to check pressure during start-up and periodically during operation.

If unit is infrequently used or periodically stored, seals may become dry. Check seals before commencing operation.

The system must be purged before operation (system fluid must flow through the pump without discharge restriction) to assure full system pressure is reached.

Optimum performance of chemical injector occurs with a 35 ft. high pressure hose and a minimum 3/8" I.D. The type of hose, extended lengths, reduced I.D. and fittings may create back pressures in excess of the low pressure nozzle rating and prevent the injector from drawing chemical. See Hose Friction Loss Chart in High Pressure Guide. **Deduct hose friction loss from above low PSI Nozzle. Consult factory for assistance with other options.**

### CAUTION:

Deduct the pressure drop shown in the performance chart from your desired system pressure to arrive at the maximum high pressure nozzle rating. This is essential to avoid over-pressurizing the pump.

**Chemical draw occurs under low pressure.** Select the Dual Nozzle (32149), Adjustable Nozzle (32151), or Vari-Nozzle (7940-7980) to permit the adjustment from low to high pressure.

For optimum performance when using a chemical injector, use a **single wire braid hose** on the discharge line. Too flexible a hose will prevent the unloader from receiving the full pressure signal to activate the by-pass mode.

For correct nozzle selection, **read system pressure at the pump. DO NOT READ SYSTEM PRESSURE AT THE HIGH PRESSURE GUN.** Incorrect pressure reading may result in: pump operation at excessive pressures, inconsistent chemical draw or possible damage to the pump or unloader.

## 5DX DIMENSIONAL

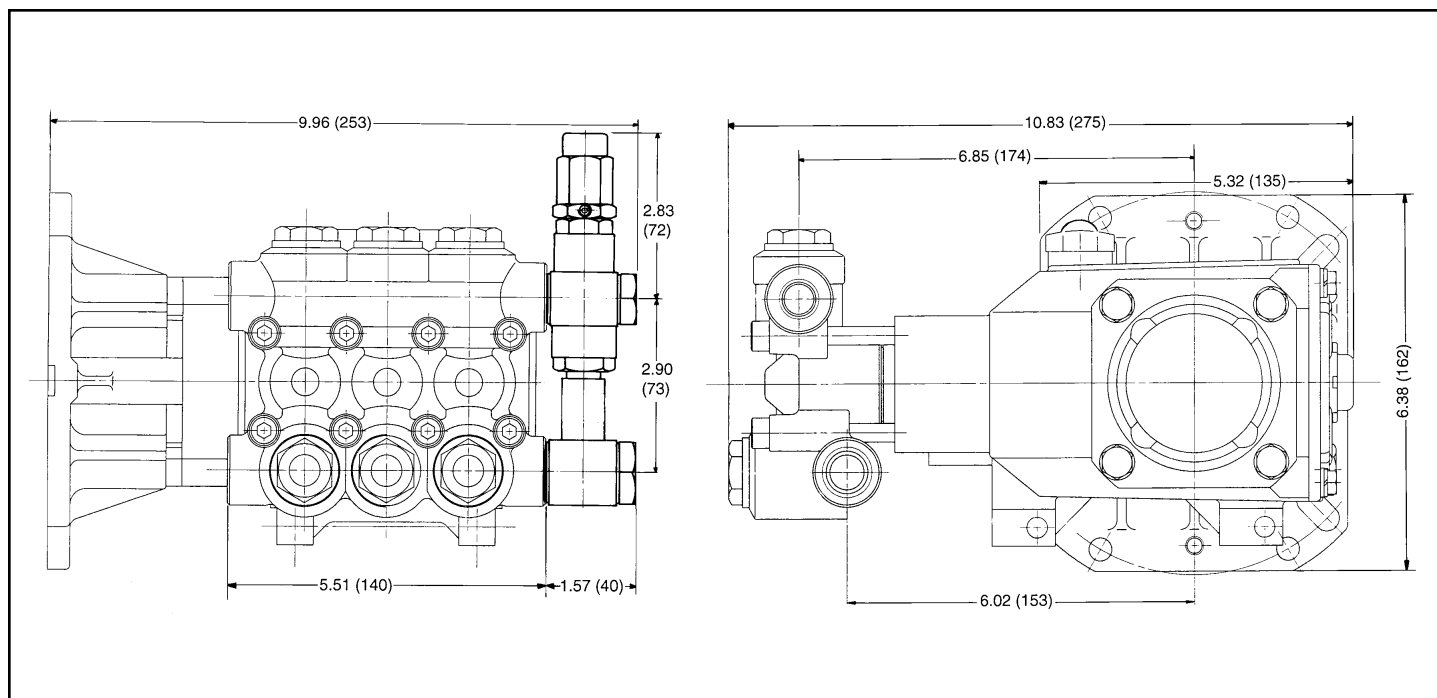

Products described hereon are covered by one or more of the following U.S. patents 3558244, 3652188, 3809508, 3920356, 3930756 and 5035580

June 1999 5977

### World Headquarters

#### CAT PUMPS

1681 - 94th Lane N.E. Minneapolis, MN 55449-4324

Phone (612) 780-5440 — FAX (612) 780-2958

e-mail: sales@catpumps.com

www.catpumps.com

### International Inquiries

FAX (612) 785-4329

e-mail: intlsales@catpumps.com



The Pump with "Nine Lives"

### CAT PUMPS (U.K.) LTD.

1 Fleet Business Park, Sandy Lane, Church Crookham, Fleet

Hampshire GU13 0BF, England

Phone Fleet 44 1252-622031 — Fax 44 1252-626655

### N.V. CAT PUMPS INTERNATIONAL S.A.

Heiveldkens 6A, 2550 Kontich, Belgium

Phone 32-3-450.71.50 — Fax 32-3-450.71.51

e-mail: cpi@catpumps.be www.catpumps.be

### CAT PUMPS DEUTSCHLAND GmbH

Buchwiese 2, D-65510 Idstein, Germany

Phone 49 6126-93030 — Fax 49 6126-930333

e-mail: catpumps@t-online.de www.catpumps.de